

XK3118K18-B

2017

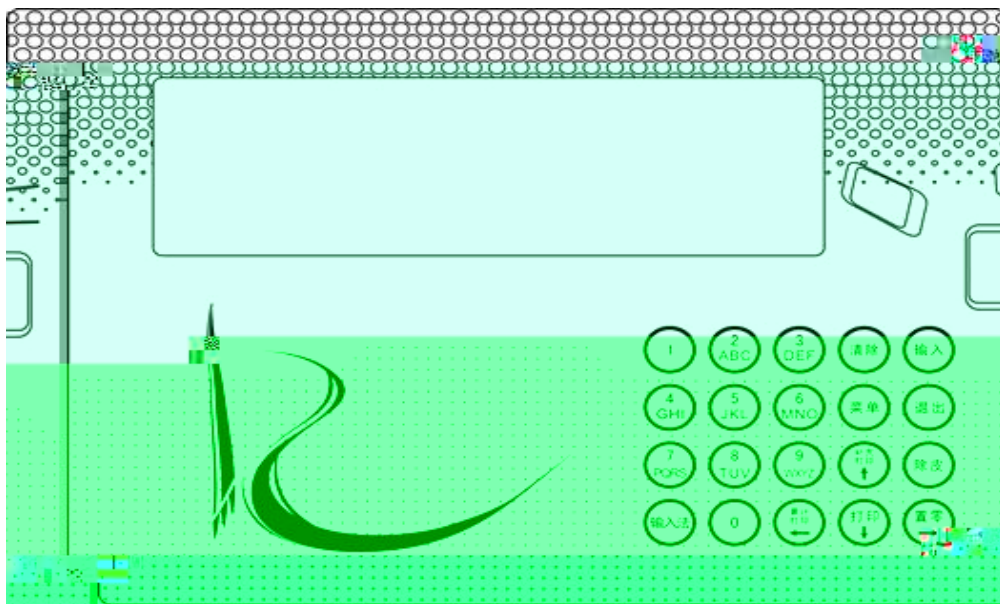

00000577

()



<http://www.kelichina.com>

1

GB/T 7724-2008 n=3000
 (III) p_i=0.5
 1.2uV/e
 A/D 24bit
 DC 5V 1 12 ÊFÇK
 6 50
 240×64 LCD
 / / / /
 /RS232 600bps 30

 RS232 RS232 30
 1200/2400/4800/9600/19200
 KX P1121 KX P1131 LQ300K
 LQ1600K LQ-680K DS-300 LQ-730K/630K/635K

 500 800

 AC187 242V 50Hz

 0 40 85 RH

 20 60 95 RH
 (mm) 330 ×220 ×185
 (Kg) 1.5

2

2.1

XK3118K18

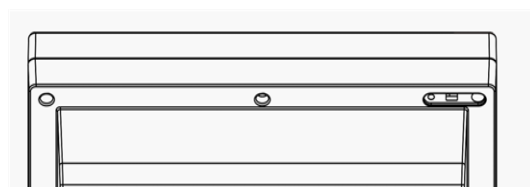
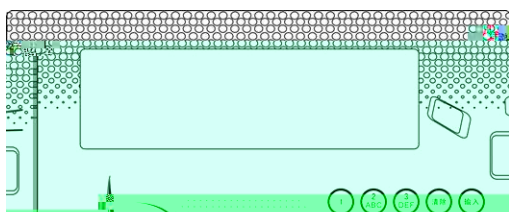

2.2

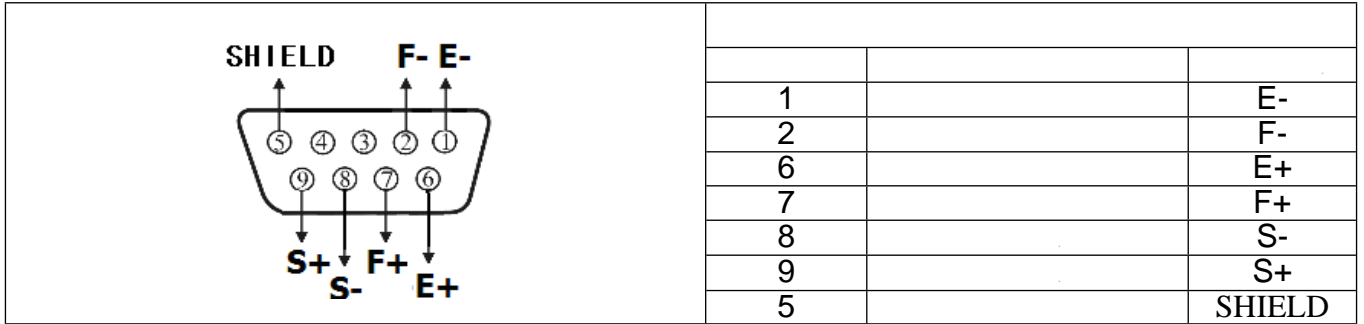

▲

▲

2.3

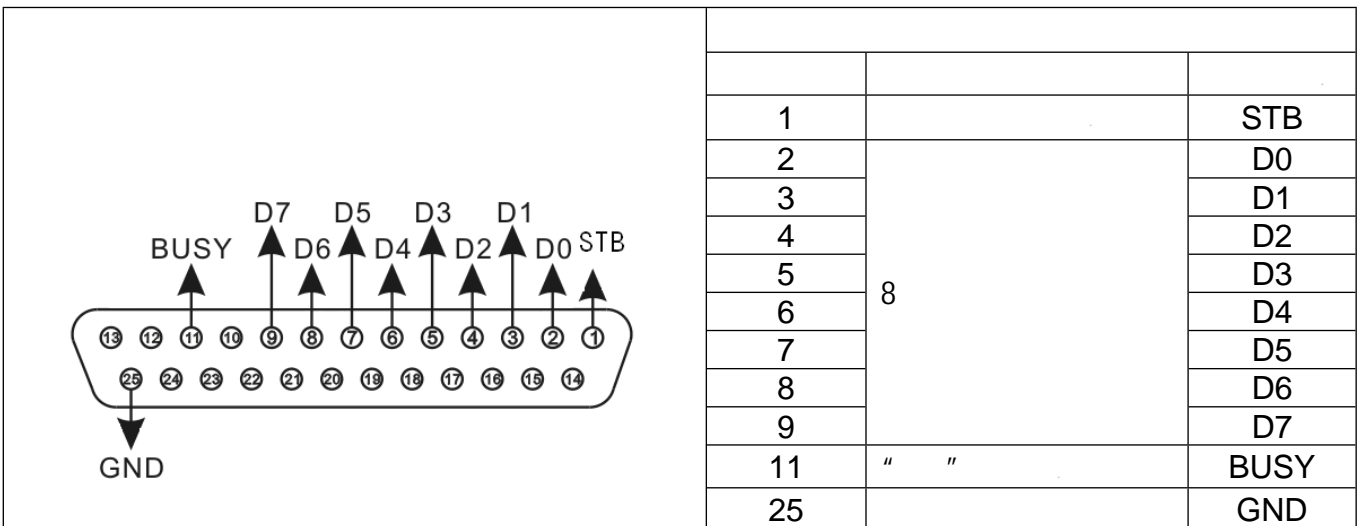

2.4

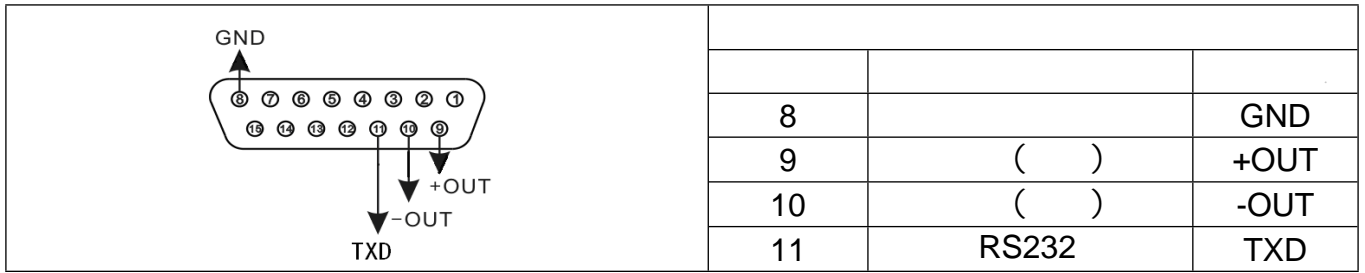

2.5

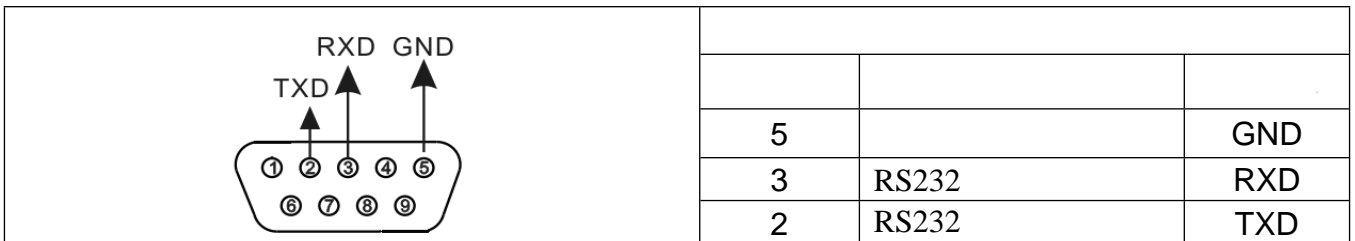

RS232

3 □

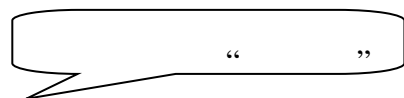
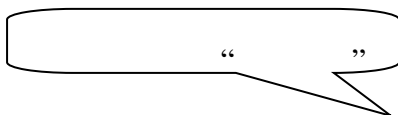

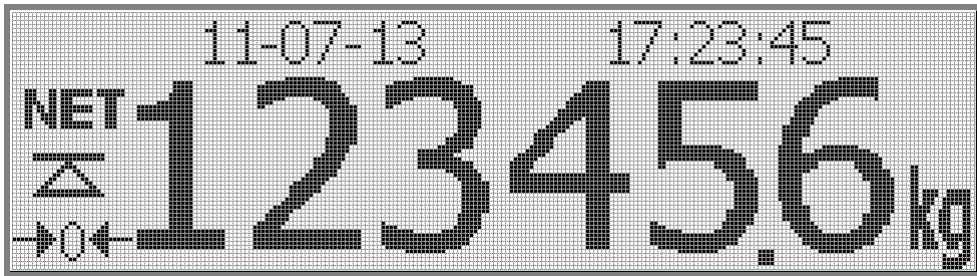

4□



4.1

4.1.1

1

2

4.1.2 ()

1 []

2 , [] []

3

4.1.3

[]

0

1

2 []

3 []

4.2

[] 6 “ ” “ ” “ ” “ ” “ ”

” “ ” “ ”

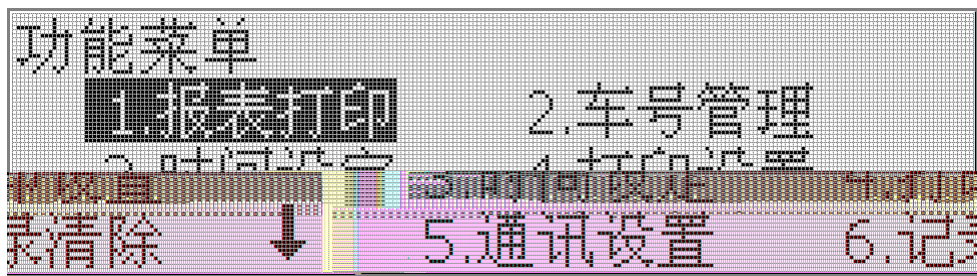

4.2.1

4.2.2

[]

5

500

4.2.3

4.2.4

4.2.5

4.2.6

4.3

1 1 6 5
 2 ()
 3

4 [] “
 ”
 5 []



“ ≤0 ≤0 ” “*”

1

ASCII 10 1 10 8

:

12

X			
1	02(XON)		
2	+ -		
3			
8			
9	0 4		
10			2 3 8 9
11			
12	03(XOFF)		

:

X	
1	02(XON) 开始
2	A Z
3	A I A B
	C D E
	F G H I
4	
5	
6	03(XOFF)

X	
1	02(XON)
2	A Z
3	A I A B C
	D E
	F G H I
4	
n	
n+1	
n+2	
n+3	03(XOFF)

4 n

A		6
B	a (+ -)	14
	b h 6 1	
C	a (+ -)	14
	b h 6 1	
D	a (+ -)	14
	b h 6 1	

4 4 9 30h ASCII 4 9 37h ASCII 4 6 30h 36h ASCII 6 4 B 37h 42h ASCII

2:

0001
12-01-08
20:08:00
71888

0001
12-01-08
20:08:00
71888

0001
12-01-08
20:08:00
71888

	APPL F
	8000(kg)
	1300(kg)
	6700(kg)

	APPL F
	8000(kg)
	1300(kg)
	6700(kg)

	APPL F
	8000(kg)
	1300(kg)
	6700(kg)

					(kg)	(kg)	(k
0001	12-01-08	20:08:00	B. ZJ888	APPL F	8000	1300	6700
0002	12-01-08	20:19:21	B. AK047	ORANG	9000	1300	7700
0003	12-01-08	20:24:33	B. BMW86	BANAN	8600	1500	7100

(5)

WEIGHT BILL	
1	Operator
SERIAL No.	123
DATE	08-08-08
TIME	20:14:56
VEHICLE	GD342
CARGO No.	CACO3
重 GROSS	1580 kg
重 TARE	80 kg
DISCOUNT	10 %
重 NET	1350 kg
REMARK	

3

1		1	
2		1	
3		1	
4		1	
5	9 D	1	
6	9 D	1	
7	0.5A	1	
8		1	

1		A5	A4
2		70g	200g
3			
4			
5		70g	80g
6			
7			